

**CITY OF LONDON SCHOOL  
ENTRANCE EXAMINATION  
(for entry in September 2009)  
SCIENCE - GROUP 3**

**Time allowed: one hour.**

*The paper is divided into 2 sections.*

*Section A contains 28 short answer questions. You are to answer all 28.*

*Section B contains longer questions. You are to answer any 4 of these.*

*The answers are to be written in the spaces provided.*

*Calculators may be used.*

*The numbers in brackets are the marks for each part of the question.*

*There is a max. of 40 marks for section A and 40 for section B.*

**ANSWER ALL QUESTIONS IN SECTION A, AND CHOOSE 4 FROM SECTION B.**

**Name:**

.....

**Candidate Number:**

.....

**SECTION A**  
**Answer all questions**

For each question 1 to 13, choose the **best** answer A, B, C or D and write it in the box.

1. The diagram shows the outline of a human. In which part are the kidneys found?

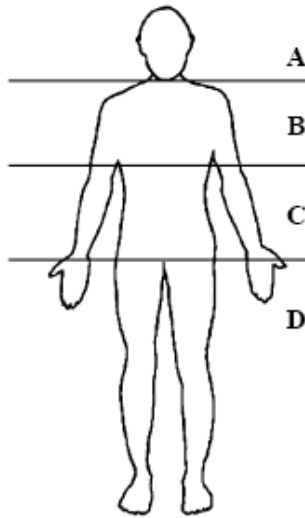

(1)

2. Seeds germinate (sprout) best in soil that is

- A dry and cold
- B moist and cold
- C dry and warm
- D moist and warm

(1)

3. The list shows substances that may be found in rivers.

sewage
nitrate
oxygen

How many of the substances in the list can cause pollution?

- A 0
- B 1
- C 2
- D 3

4. Living organisms do **not** include

(1)

- A plants
- B fungi
- C rivers
- D viruses

5. The diagram shows some animal cells.

(1)



Part **X** is the

- A nucleus
- B cytoplasm
- C cell membrane
- D cell wall

(1)

6. The diagram shows part of the thorax of the human body.

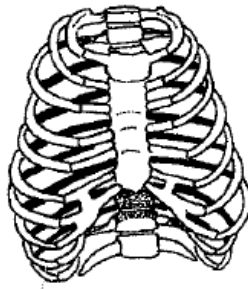

The name of this part is the

- A diaphragm
- B lung
- C bronchus
- D ribcage

(1)

7. The diagram shows how gas exchange takes place between an alveolus in the lungs and the blood.

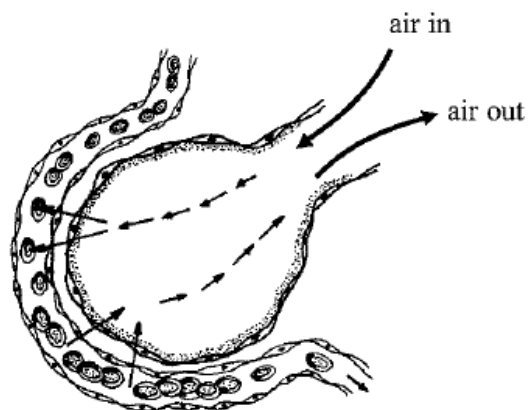

Gas exchange takes place by

- A osmosis
- B diffusion
- C active transport
- D evaporation

(1)

8. Which part of the blood carries oxygen?

- A red cells
- B white cells
- C platelets
- D plasma

(1)

9. Plants make food in a process called photosynthesis.

The gas used in photosynthesis is

- A oxygen
- B nitrogen
- C hydrogen
- D carbon dioxide

(1)

10. The diagram shows the organs of the body.

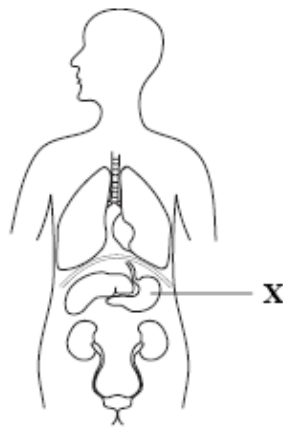

X is

- A heart
- B lung
- C kidney
- D stomach

(1)

11. The brain is part of the

- A nervous system
- B reproductive system
- C circulatory system
- D excretory system

(1)

12. The list gives three processes.

<b>nutrition</b>	<b>reproduction</b>	<b>respiration</b>
------------------	---------------------	--------------------

How many of these processes are carried out by all animals?

- A none
- B one only
- C two only
- D all of them

13. Which is the smallest?

- A a cell
- B an organ
- C an organelle
- D an organism
- E a tissue

(1)

(1)

14.

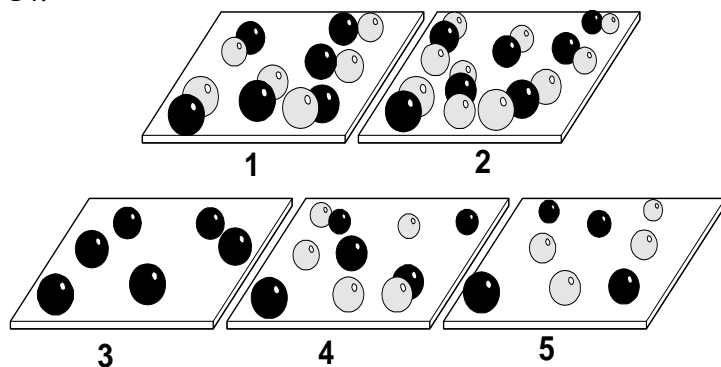

Which one of these diagrams 1-5 represents

- (a) an element? .....(1)
- (b) a pure compound? .....(1)
- (c) a mixture of elements? .....(1)
- (d) a mixture of compounds? .....(1)
- (e) a reaction between two elements which has not completed? .....(1)

15. Choose **from the list** the most suitable method for each of the following separations.

- chromatography      dissolving
- distillation          evaporation
- filtration              fractional distillation

- (a) To separate ethanol from wine.  
.....
- (b) To obtain some solid salt from a solution of salt in water.  
.....
- (c) To separate a mixture of different coloured inks.  
.....
- (d) To obtain a sample of pure water from some tap water.  
.....
- (e) To obtain sand from a mixture of sand and water.  
..... (5)

16. A class studied five different metals labelled A, B, C, D and E. The experiments were divided up so that the teacher did some of them and the pupils did the others. The table below shows the results of the experiments.

METAL	RESULT OF HEATING IN AIR	REACTION WITH COLD WATER	REACTION WITH STEAM	REACTION WITH DILUTE ACID
A	Did not burn. Oxide formed on surface.	No reaction.	Slow reaction.	Slow reaction.
B	No reaction.	No reaction.	No reaction.	No reaction.
C	It burned violently. Oxide formed.	Bubbles of hydrogen were quickly produced.	NOT ATTEMPTED	NOT ATTEMPTED
D	Did not burn. Oxide formed on surface.	No reaction.	No reaction.	No reaction.
E	It burned quickly. Oxide formed.	A few bubbles on the surface of the metal.	Vigorous reaction. Hydrogen and oxide produced.	Dissolved quickly. Hydrogen produced.

- (a) Use the results of the experiments to place the five metals, A to E, in an order of reactivity.

Most reactive .....

.....

.....

.....

Least reactive .....

(4)

- (b) Suggest a reason why the teacher did not test the reactions of C with steam and acid.

.....

.....

(1)

17. A teacher passes you a book across a desk. It slides for a while before coming to rest. What is the name of the force that slowed and stopped the book?

..... (1)

18. The density of a substance can be found by using the following formula:

$$\text{Density} = \frac{\text{Mass}}{\text{Volume}}$$

If a block of wood has a volume of 150cm<sup>3</sup> and a mass of 120g, calculate the density of the wood.

.....g/cm<sup>3</sup> (1)

19. Magnets can be used to distinguish between steel and aluminium cans for recycling purposes. Explain how this can be done.

.....  
.....(1)

20. The North-seeking pole of a magnet is held near to an iron nail. The iron nail is attracted towards the magnet. Describe what happens when the opposite (South-seeking) pole is brought close to the iron nail.

.....(1)

21. Put the following objects in space into order, starting with the closest to the Earth, and finishing with the furthest away.

Neptune      The Sun      Another galaxy      Another star      The Moon

.....(1)

22. In a lightning storm, you see the flash of the electrical discharge long before you hear the thunderclap. What does this tell you about the relative speed of light and sound through the atmosphere?

.....  
.....(1)

23. What are the units of mass, and what are the units of weight?

.....  
.....(1)

24. Explain what must occur in order for there to be a total solar eclipse seen from the Earth.

.....  
.....(1)

25. Circle the good electrical conductors in the following list of substances:

Glass      Copper      Polythene      Salt solution      Wood      (1)

26. Name the force which is responsible for keeping a boat afloat.

..... (1)

27. It is easier to cut through an apple using a sharp knife than a blunt knife. Use the idea of pressure, and the formula:  $pressure = \frac{force}{area}$  to explain why.

.....  
.....  
.....(1)

28. Why must there be a force on the Moon as it orbits the Earth?

..... (1)

***This completes the compulsory section of the paper. You must now attempt any four of the remaining questions. Follow the instructions on page 12.***

SECTION B

Answer 4 questions only. Tick 4 boxes to show which questions you have chosen.

**B1**

**B2**

**B3**

**B4**

**B5**

**B6**

**B1.** The picture shows a student using an exercise machine.

Seven female eighteen-year-old students took part in an investigation using this exercise machine. They investigated how breathing rate is affected by the length of time they exercised.

The breathing rate of each student was measured at rest. The students then exercised for 2 minutes and their breathing rate was measured immediately after this. The students then had 10 minutes to recover from the exercise.

The students then exercised for 4 minutes and their breathing rate was measured immediately after this. The students had a further 10 minutes to recover.

This sequence was repeated for 6 minutes of exercise, then 8 minutes of exercise and finally for 10 minutes of exercise.



(a) (i) Give two ways in which the students made this investigation a fair test.

1.....

.....

2.....

.....

(ii) Why is it important to make the investigation a fair test?

.....

..... (3)

(b) The table shows the results of the investigation for the seven students. The mean (average) result is also shown in the table.

Length of time of exercise in minutes	Breathing rate in breaths per minute							
	Student A	Student B	Student C	Student D	Student E	Student F	Student G	Mean (average)
0	15	13	14	14	17	16	16	15
2	17	16	17	16	18	18	17	17
4	19	25	19	18	20	20	19	20
6	21	20	20	20	22	23	21	21
8	23	22	23	22	23	24	24	23
10	24	25	25	24	25	?	26	25

(i) Calculate the missing value for student F after 10 minutes of exercise.

.....

(ii) Look at the pattern of all the results in the table. Draw a circle around one result in the table that is anomalous (unexpected).

(2)

- (c) (i) Describe the relationship between the breathing rate and the length of time of exercise.

.....  
.....

- (ii) Using your biological knowledge, explain the relationship between breathing rate and length of time of exercise.

.....  
.....  
.....  
.....  
.....  
..... (5)

**B2.** A farmer had some wheat seeds that were 20 years old. He wanted to know if age has an effect on germination ('sprouting') of wheat seeds. He asked some students in a local school if they could find out the answer.

The students obtained wheat seeds of different ages. They put ten seeds of each age on to wet cotton wool in dishes. The seeds were left to germinate for five days and the results are shown in the drawings.

**Key**

☞ = germinated seed

○ = seed not germinated

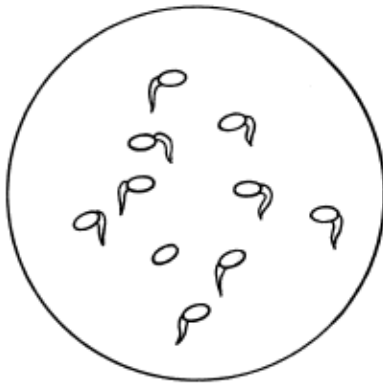

1-year old seeds

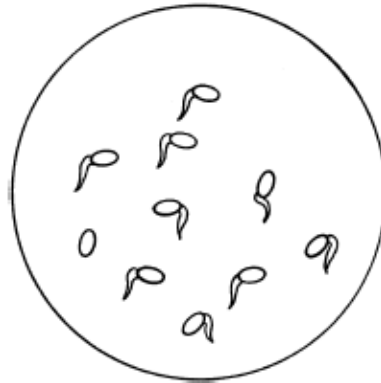

4-year old seeds

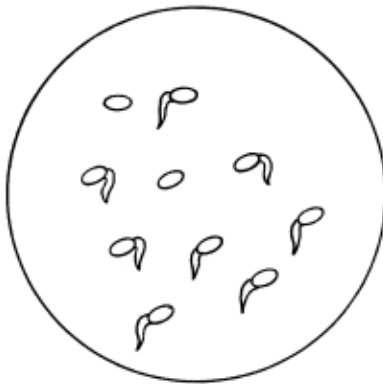

8-year old seeds

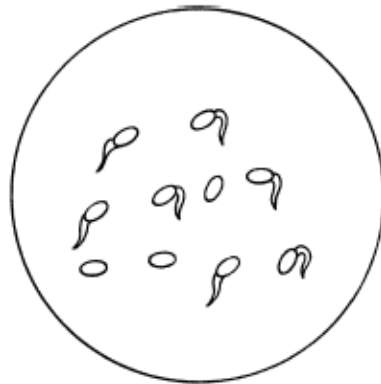

12-year old seeds

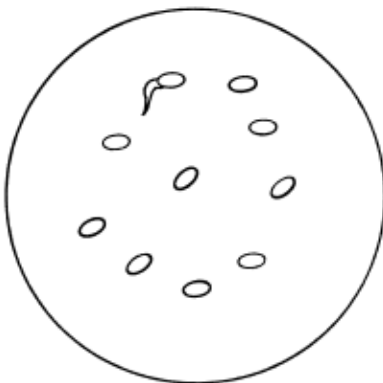

16-year old seeds

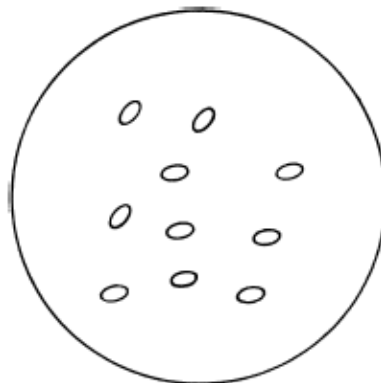

20-year old seeds

- (a) Use the information in the drawings to complete the table below. The first one has been done for you.

Age of wheat seeds in years	Number of germinated seeds	Number of seeds not germinated
1	9	1
4		
8		
12		
16		
20		

(2)

- (b) The students also produced a table showing the percentage of the seeds that germinated. This table is shown below, but is not complete.

Complete the table by calculating the percentage germination for 12-year-old seeds. Put your answer into the empty box in the table.

Age of wheat seeds in years	Percentage of seeds that germinated (%)
1	90
4	90
8	80
12	
16	10
20	0

(1)

(c) On the grid plot a line graph to show how the percentage of seeds that germinated changed with the age of the seeds.

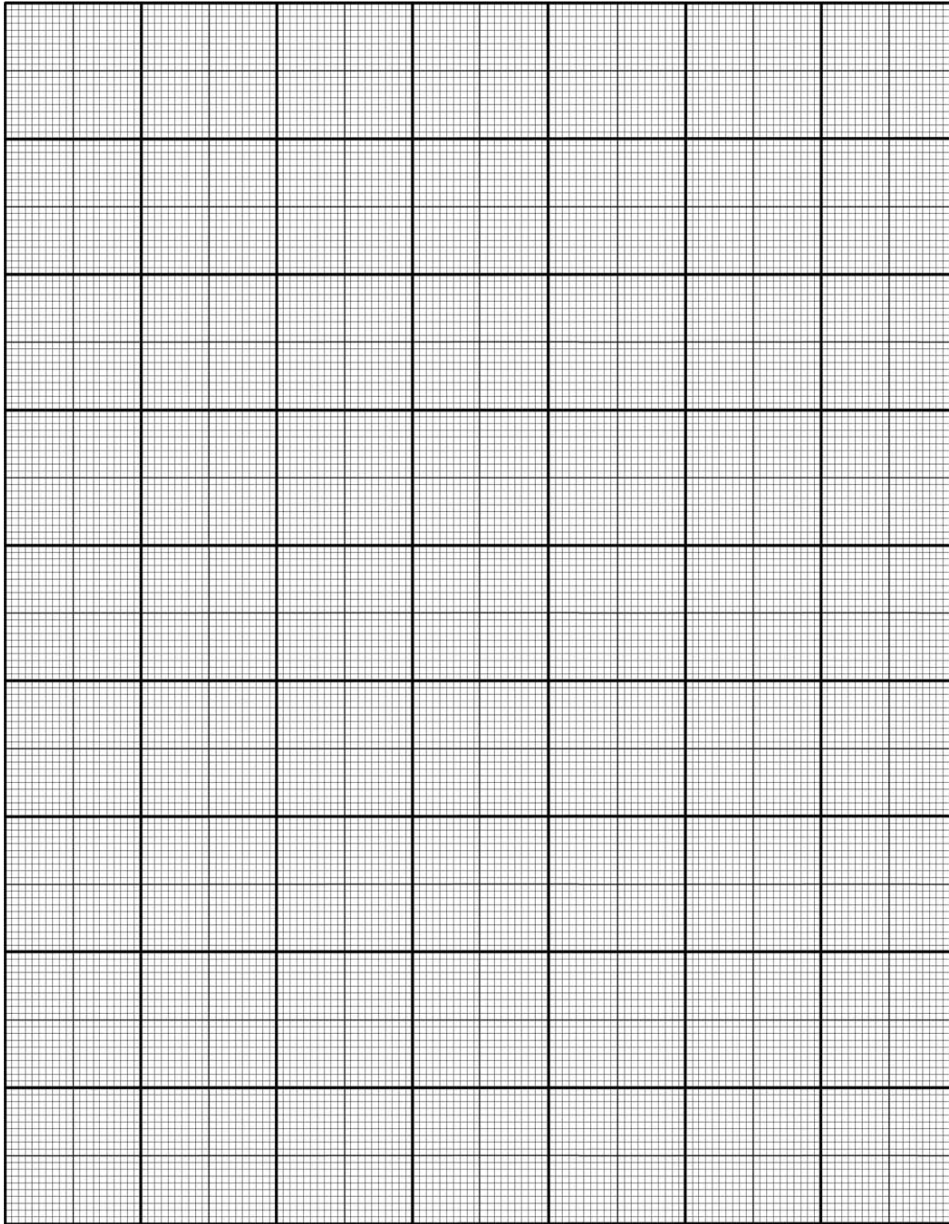

(d) What advice should the students give to the farmer about using his 20-year-old seeds? Explain your answer. (4)

.....

.....

.....

(3)

**B3.** A student did two experiments to test some river water.

(a) The first experiment was to measure the amount of solid particles in the water. The method used is given below.

STEP 1 A piece of dried filter paper was weighed.

STEP 2 1000 cm<sup>3</sup> of the river water was poured through the filter paper.

STEP 3 The filter paper plus solid particles was then dried and weighed.

The results are shown below.

The mass of the dried filter paper plus solid particles = 3.150 g

The mass of the dried filter paper = 3.120 g

(i) What was the mass of solid particles in the sample of water?

..... g

(ii) Why does the filter paper have to be dried before weighing?

.....

(iii) If the filter paper was not completely dry what effect would this have on the mass of solid calculated?

.....

(iv) The table below gives information about water quality.

WATER QUALITY	AMOUNT OF SOLIDS (g per 1000 cm <sup>3</sup> of water)
clean water	less than 0.005 g
recovering river	between 0.005 and 0.020 g
polluted river	between 0.020 and 0.050 g
crude sewage	greater than 0.350 g

Use the table to state the water quality of the sample of river water tested.

Water quality .....

(4)

(b) The student then did a second experiment. The student boiled some of the filtered water from the first experiment. The diagram below shows the apparatus the student used.

- (i) Label the two pieces of apparatus indicated by lines, using words from this list.
- |                   |        |
|-------------------|--------|
| evaporating basin | tripod |
| beaker            | mat    |
| conical flask     | gauze  |

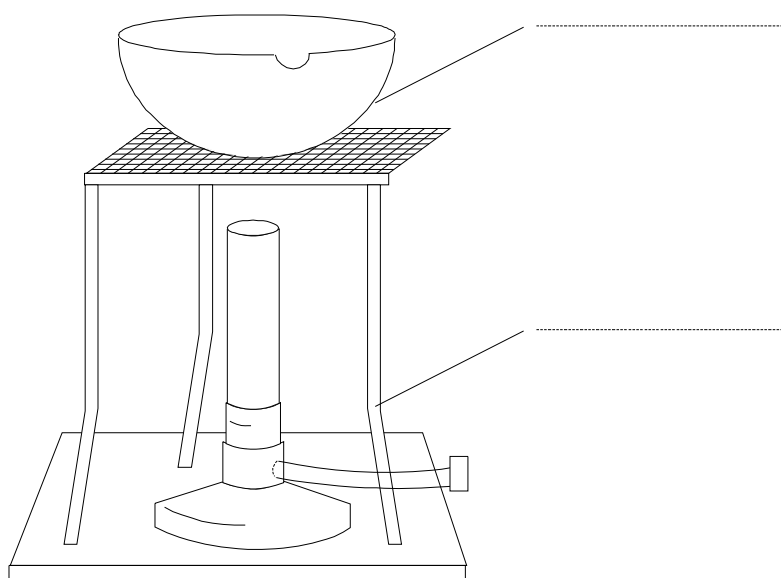

- (ii) At the end of the experiment only a dry solid was left. The report below was taken from the student's book. There are some words missing. Complete the report using words from this list.

condensed	impure
dissolved	pure
evaporated	solution

Some of the clear filtered water was heated until the water had .....  
and some solid was obtained from the water. This shows that the water could not  
have been ..... It must have been a .....  
of the solid ..... in the water.

(6)

**B4.** Distillation has been used in some parts of the world to obtain drinking water from sea water. The diagram shows a small scale distillation apparatus that could be used to demonstrate this process in a school laboratory.

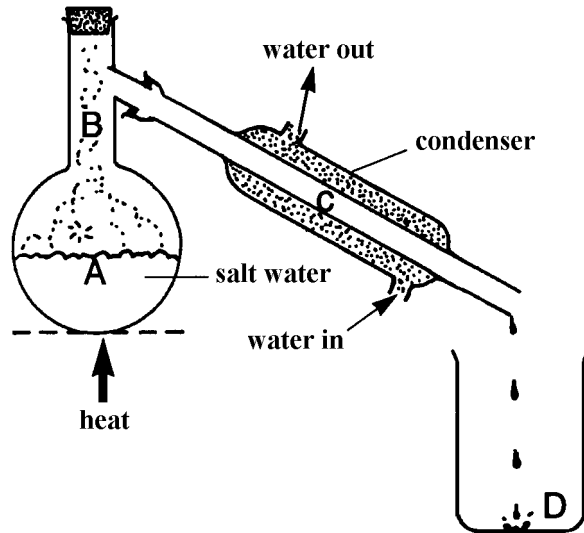

- (a) Explain, as fully as you can, how the apparatus makes drinking water from salt water. You may use the letters A, B, C and D to help with your answer.

.....

.....

.....

.....

.....

.....

(4)

- (b) Why is this method of making drinking water very expensive?

.....

(1)

(c) Bottled water is sold throughout the world.

(i) Draw a line to join each labelled part to the arrangement of its particles.

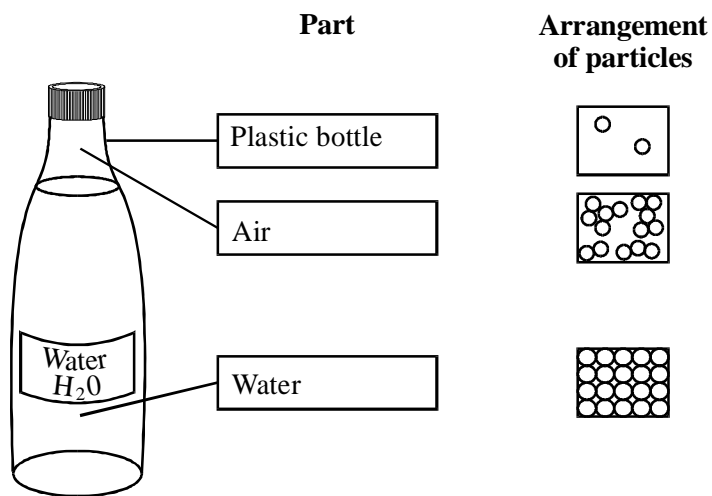

(ii) Use **one** of the words in the box to complete the sentence.

ice    liquid    steam    vapour

The bottle of water was put into a freezer to cool it down. It was left too long, so the water changed to .....

(3)

(d) Write **two** things that the chemical formula H<sub>2</sub>O tells you about water.

1. ....
- .....
2. ....
- .....

(2)

**B5.** The following data shows how the position of a car varies with time.

<b>Distance from fixed position /m</b>	<b>Time /s</b>
0	0
5	1
10	2
15	3
15	4
15	5
15	6
25	7
35	8

(a) Describe the motion of the car between the time of 3 seconds and 5 seconds

.....(2)

(b) Calculate the probable speed of the car during the first 3 seconds of motion.

.....(2)

(c) How far was the car from the fixed position after 7 seconds?

.....(1)

(d) Estimate the car's distance from the fixed position after 7.5 seconds.

.....(1)

(e) Work out the **average** speed of the car over the whole time.

.....(1)

(f) Compare the speed of the car at the start of the experiment with the speed at the end.

.....(2)

(g) What might be done to show these data more clearly to anyone reading this question?

.....(1)

**B6.** The following question is about light.

(a) Fill in the missing colours which make up the visible spectrum of light.

Red Orange ..... Green ..... Indigo Violet (2)

(b) Name a natural occurrence in which Sunlight is split into all the colours of the visible spectrum.

.....(1)

(c) A ray of light is shone on to a plane mirror as shown. The angle of incidence is  $40^\circ$ . Label the angle of reflection. (1)

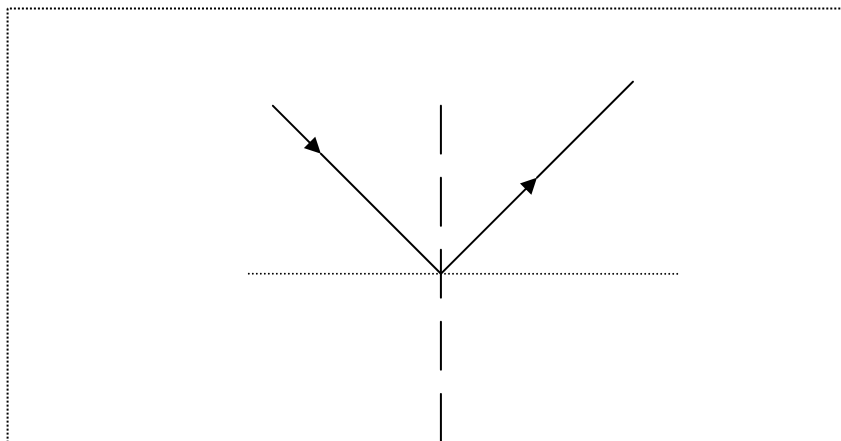

(d) What is the size of the angle of reflection?

.....(1)

(e) Explain why the Moon shines.

.....  
.....(2)

When light travels from air into water, it slows down. As a result of this, it may change its direction.

(f) What is this change in direction called?

.....(1)

(g) Complete the diagram to show how the light proceeds **in water**. (2)

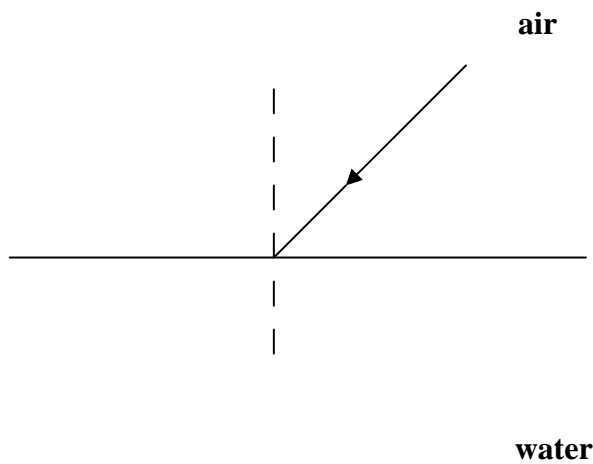

**END OF EXAM**