

IGCSE Mathematics Revision

Session 7

4.8 Trigonometry	<p>understand and use sine, cosine and tangent of obtuse angles</p> <p>understand and use angles of elevation and depression</p> <p>understand and use the sine and cosine rules for any triangle</p> <p>use Pythagoras' theorem in 3 dimensions</p> <p>understand and use the formula $\frac{1}{2}bc \sin A$ for the area of a triangle</p> <p>apply trigonometrical methods to solve problems in 3 dimensions including finding the angle between a line and a plane</p>	<p>The angle between two planes will not be required</p>
-------------------------	---	--

Diagram **NOT**
accurately drawn

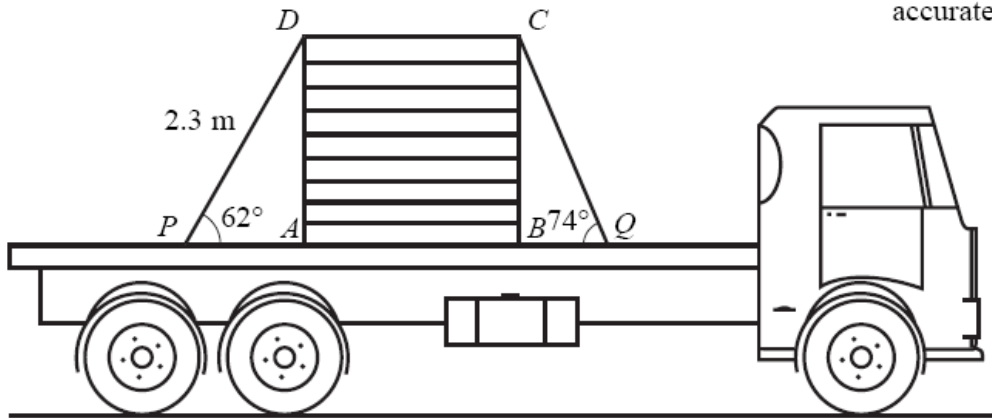

The diagram shows a side view of a rectangular box $ABCD$ on a lorry.
The box is held down on the horizontal flat surface of the lorry by a rope.
The rope passes over the box and is tied at two points, P and Q , on the flat surface.

$DP = 2.3\text{ m}$.
Angle $APD = 62^\circ$.
Angle $BQC = 74^\circ$.

Calculate the length of BQ .
Give your answer correct to 3 significant figures.

..... m

(Total 5 marks)

A triangle has sides of length 5 cm, 6 cm and 9 cm.

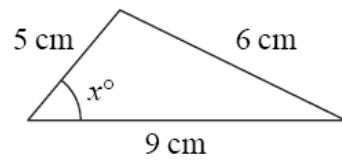

Diagram **NOT**
accurately drawn

Calculate the value of x .
Give your answer correct to 3 significant figures.

$x = \dots\dots\dots$

- (a) A farmer arranges 90 m of fencing in the form of an isosceles triangle, with two sides of length 35 m and one side of length 20 m.

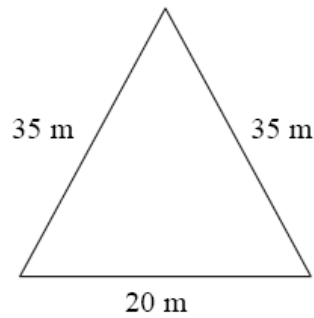

Diagram **NOT** accurately drawn

Calculate the area enclosed by the fencing.
Give your answer correct to 3 significant figures.

..... m²
(4)

- (b) Later, the farmer moves the fencing so that it forms a different triangle, ABC .

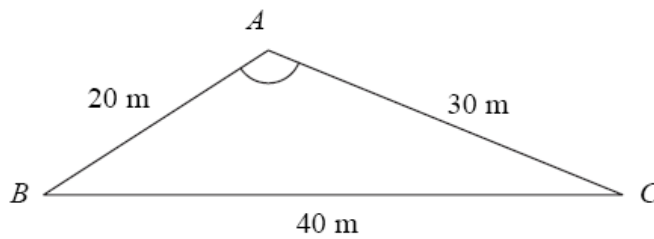

Diagram **NOT** accurately drawn

$AB = 20 \text{ m}$ $BC = 40 \text{ m}$ $CA = 30 \text{ m}$

Calculate the size of angle BAC .
Give your answer correct to 1 decimal place.

..... °
(3)

(Total 7 marks)

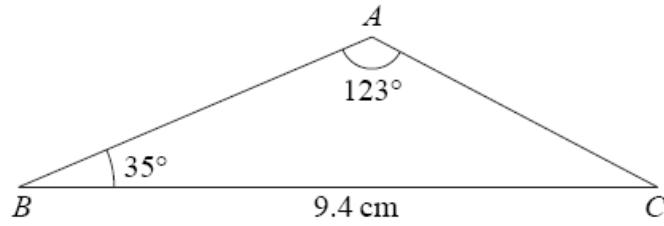

Diagram **NOT** accurately drawn

$BC = 9.4$ cm.
 Angle $BAC = 123^\circ$.
 Angle $ABC = 35^\circ$.

- (a) Calculate the length of AC .
 Give your answer correct to 3 significant figures.

..... cm
 (3)

- (b) Calculate the area of triangle ABC .
 Give your answer correct to 3 significant figures.

..... cm^2
 (3)

(Total 6 marks)

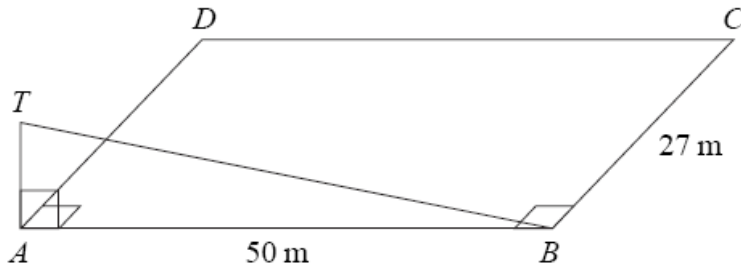

Diagram **NOT** accurately drawn

$ABCD$ is a horizontal rectangular field.

$AB = 50$ m.

$BC = 27$ m.

AT is a vertical mast.

- (a) The angle of elevation of T from B is 19° .
 Calculate the length of AT .
 Give your answer correct to 3 significant figures.

..... m
 (3)

- (b) Calculate the distance from C to T .
 Give your answer correct to 3 significant figures.

..... m
 (3)

(Total 6 marks)

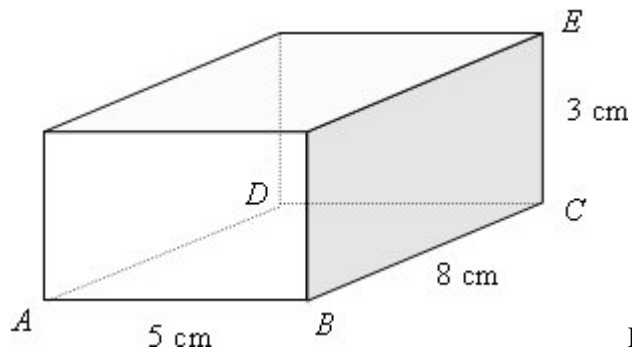

Diagram **NOT** accurately drawn

The diagram shows a cuboid.

A , B , C , D and E are five vertices of the cuboid.

$AB = 5$ cm.

$BC = 8$ cm.

$CE = 3$ cm.

Calculate the size of the angle the diagonal AE makes with the plane $ABCD$.

Give your answer correct to 1 decimal place.